

ADDRESS BUFFER AND GAL DECODING

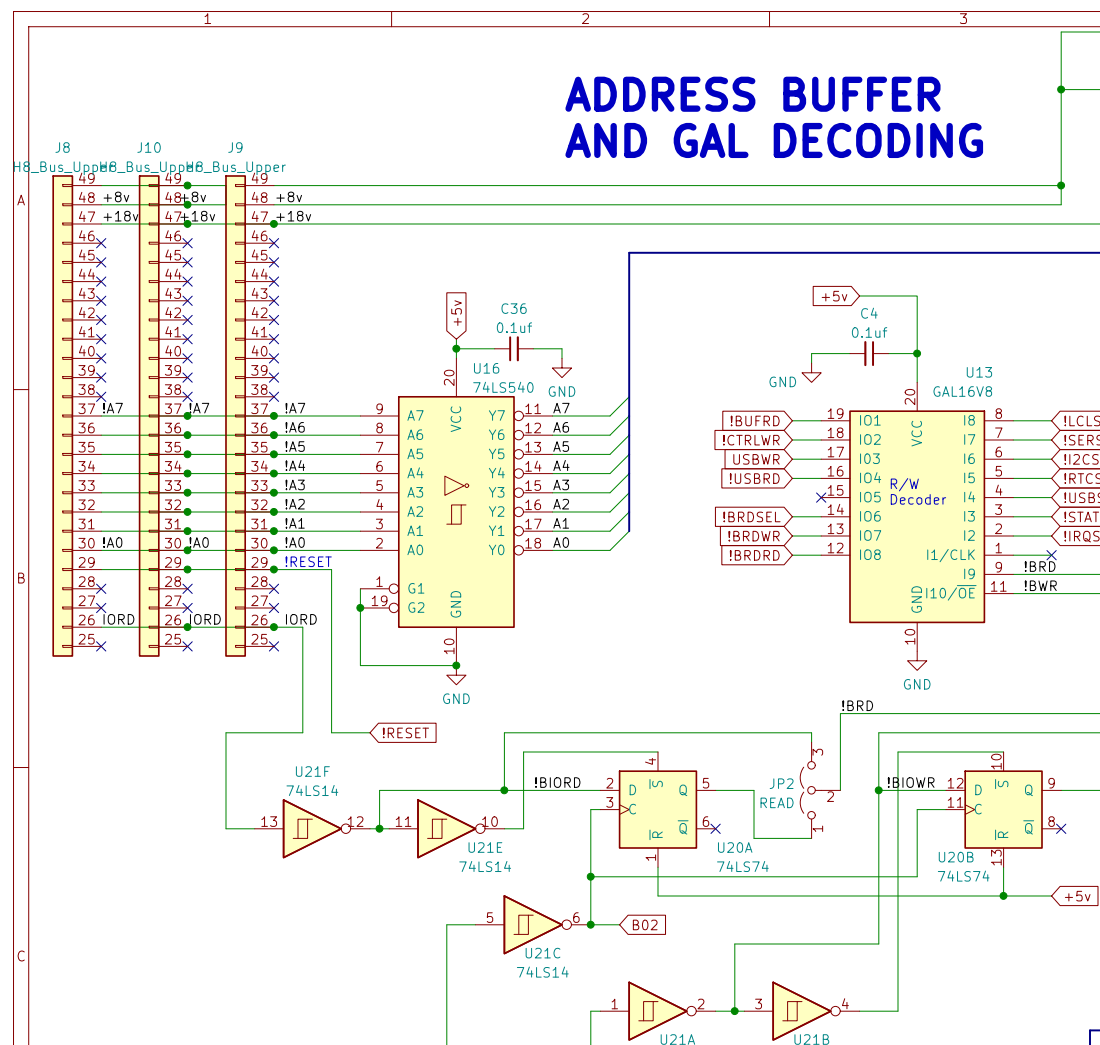

BIDIRECTIONAL DATA BUFFER

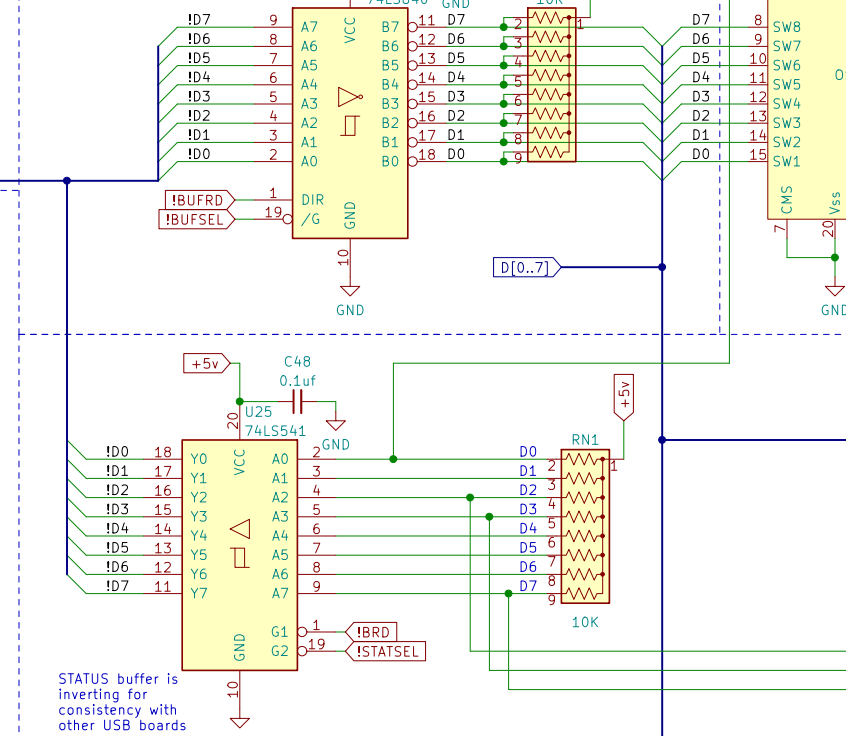

BUS INTERRUPTS

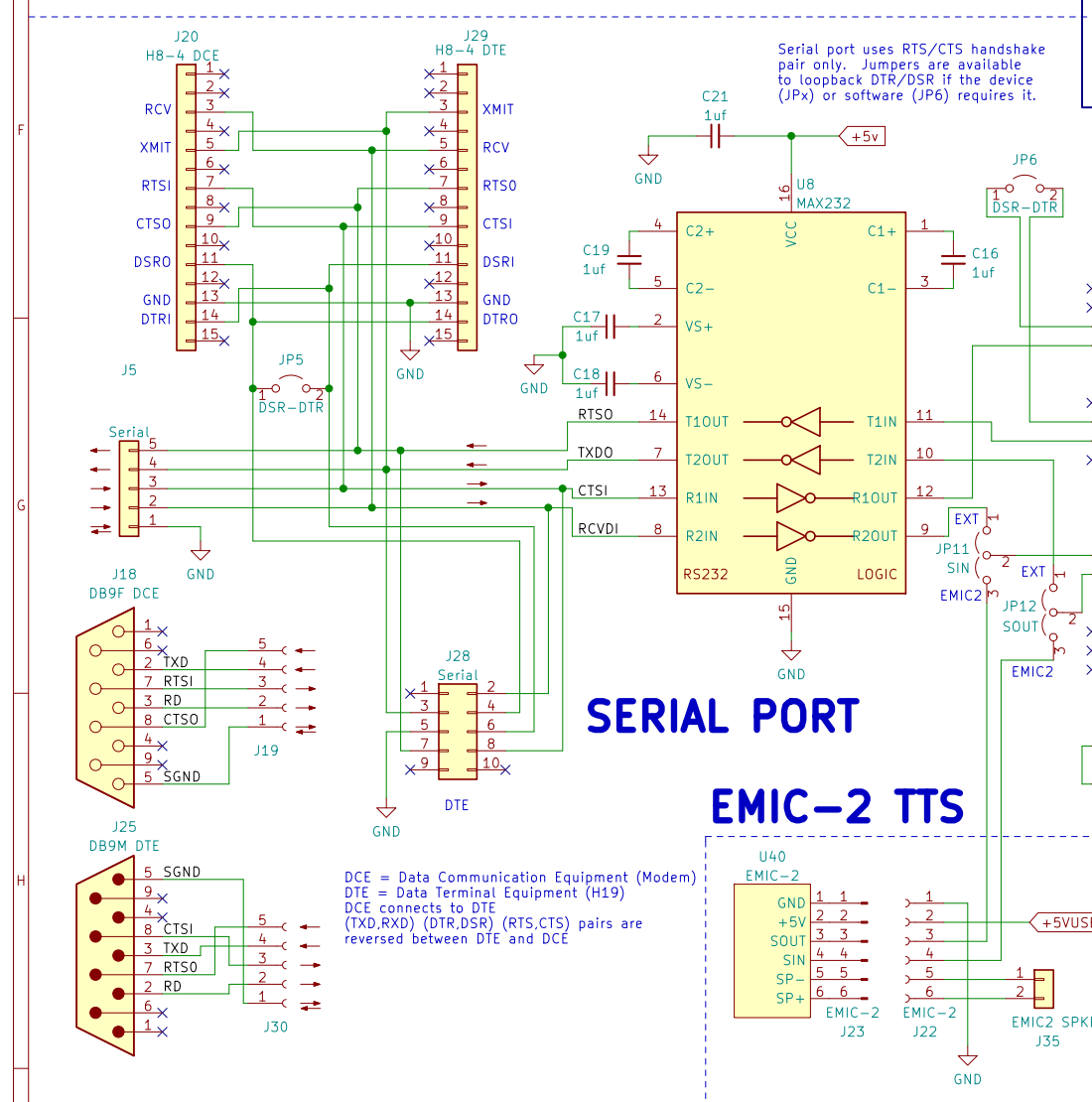

SERIAL PORT

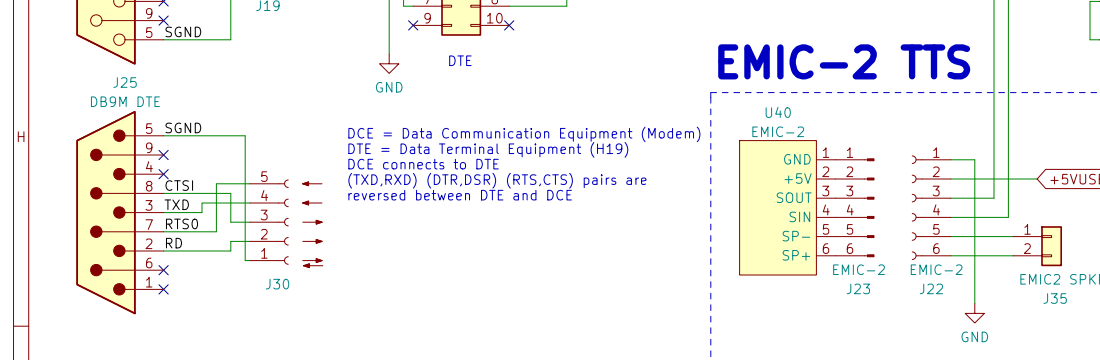

EMIC-2 TTS



STATUS READ

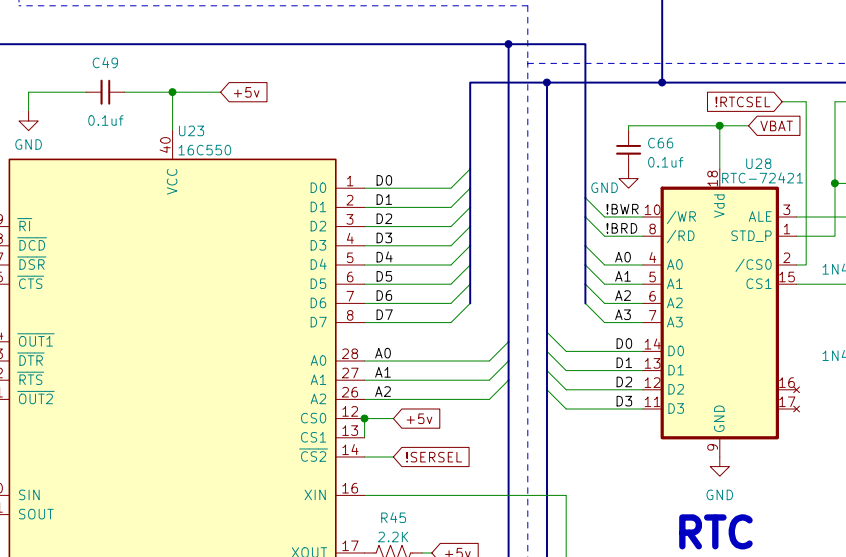

RTC I2C

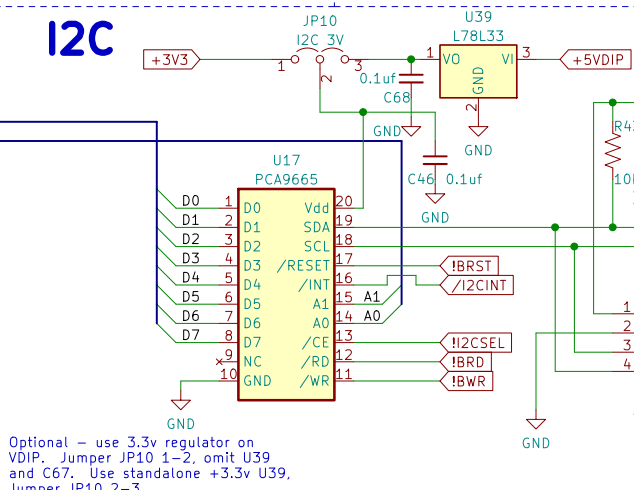

CONTROL WRITE

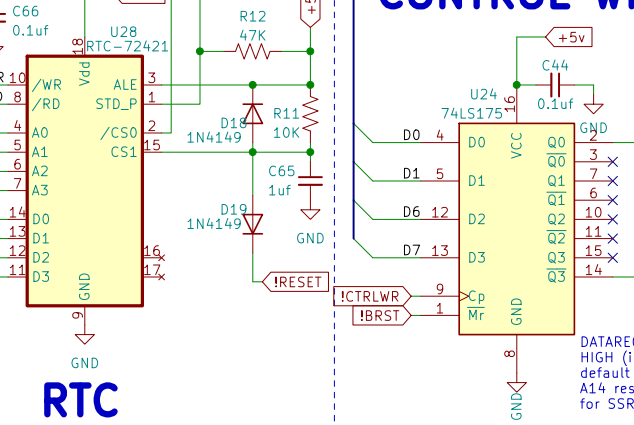

SOFT RESET

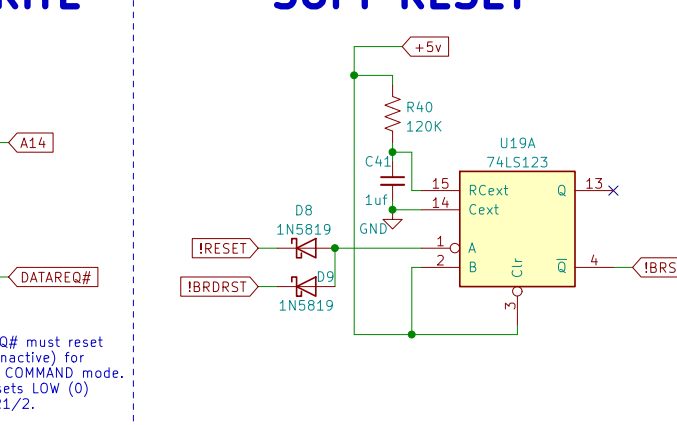

PWM

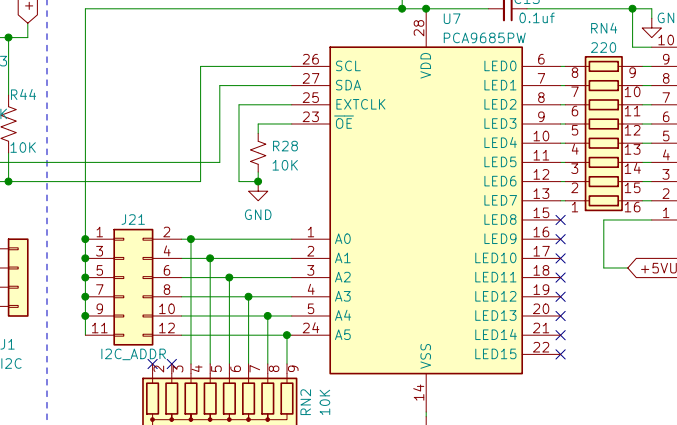

USB CONTROLLER

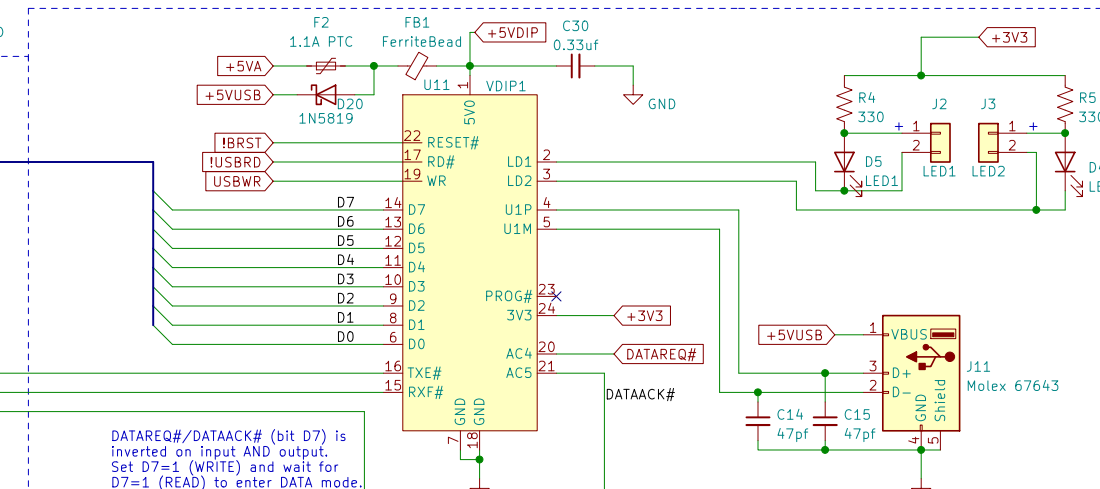

DIGITAL TALKER SPEECH SYNTHESIZER

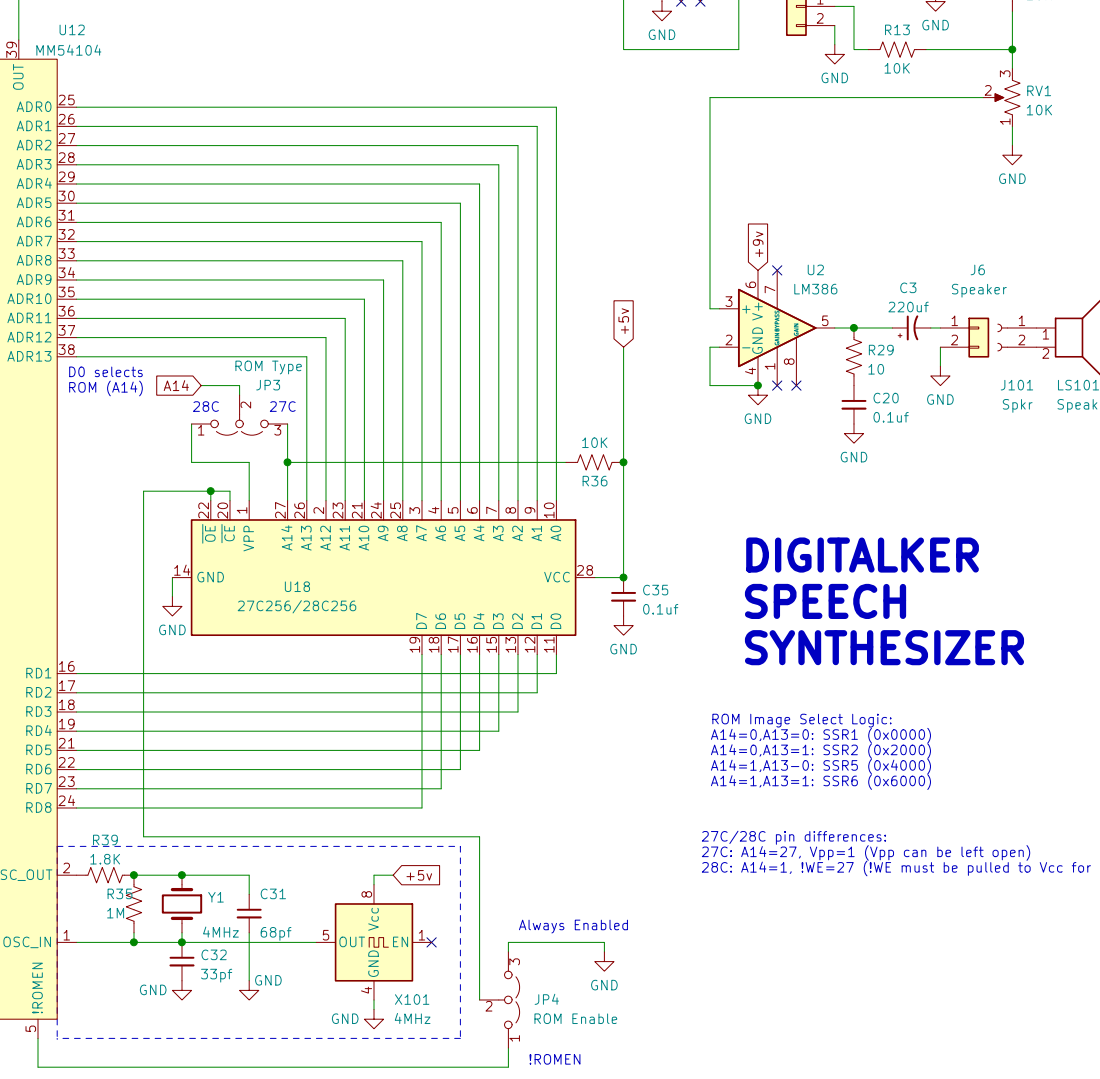

BLINKENLIGHTS CONTROLLER

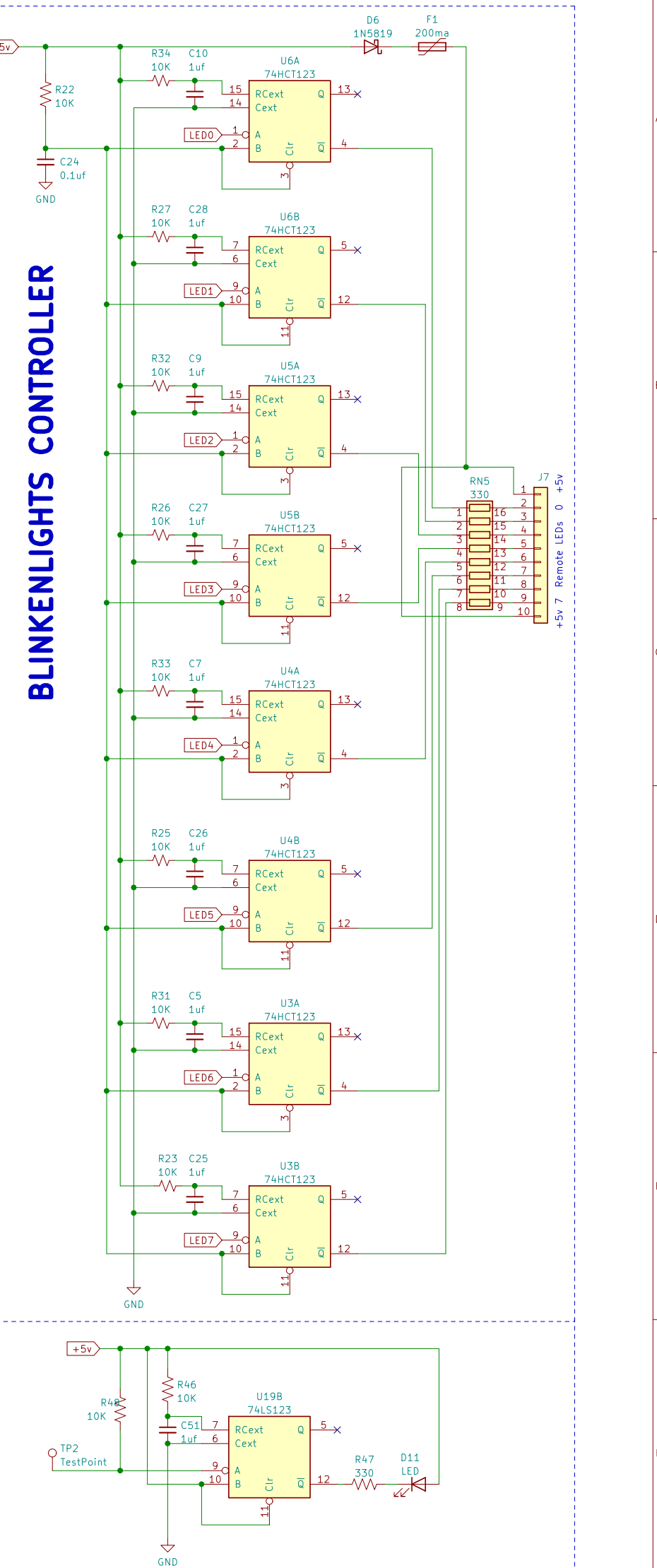

INTERRUPT CONTROLLER

